

In-Line Bander



Speed and quality are essential!

Creating a high quality finished paper banded product in the least amount of time has never been easier and more flexible! The versatile Bretting In-Line Bander can quickly band either clips or logs of folded or interfolded product. Product is fed automatically or manually into the bander by a flat belt conveyor and compressed through the use of a top and bottom belt compression system. Top and bottom banding stock will be cut, formed, and glued (or heat sealed) around the longitudinally moving product, creating a two seam banded configuration.

This in-line style bander can be integrated into new machine complexes or operated as a stand alone unit, making it possible to be positioned in any location. Profit from taking advantage of unused floor space; it is not required to place the bander at the end of a machine. Conveyor systems, accumulators and other devices can be included to complete any manual or automatic production complex.

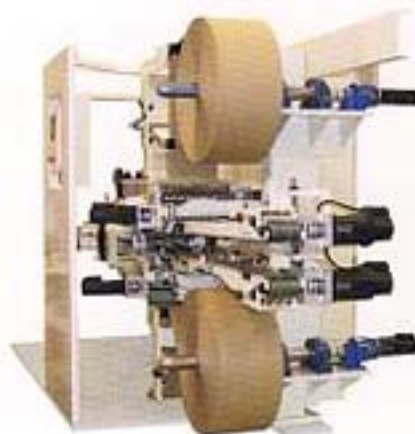
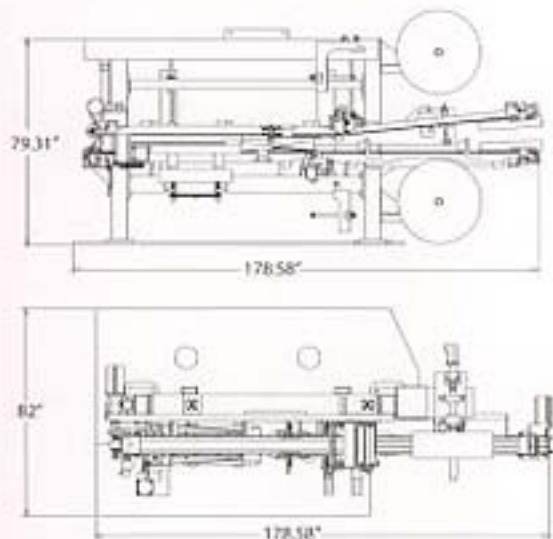

Bander Sleeve Stock:
(variable for package height)

Material:

- Paper
- Polyethylene
- Polypropylene

Width:

- 13" (330 mm) maximum

Diameter:

- 32" (813 mm) maximum

Package:

Length Range:

- 6.3" (clip) - 138" (log)
- 160 mm - 3505 mm

Width Range:

- 3.188" - 5.25"

- 81 mm - 133 mm

Loose Stack Range:

- 6" - 14"
- 152 mm - 356 mm

Compressed Stack Range:

- 3" - 7"
- 76 mm - 178 mm

Estimated Banding Speed:

Per Minute:

- 200 lineal feet
- 61 lineal meters

Options:

- Roll Loader
- Log Saw
- Accumulator



C. G. Bretting Manufacturing Co., Inc.

3401 Lake Park Road • Ashland, WI 54806

Tel: 715.682.5231 • Fax: 715.682.4138

E-mail: sales@bretting.com • www.bretting.com