

Bretting Bulk Pack Polywrapper



Reliable and versatile wrappers

The fully automatic bulk pack wrappers are some of the most reliable and versatile wrappers available today. Innovative sequential servo motor technology and rapid, easy size changeovers are part of their thoughtful design to achieve top performance in packaging bulk pack napkins using low gauge printed polyethylene or polypropylene packaging material.

The servo motors provide continual and constant positive control of the product and the wrapping material. They also minimize the utilization of mechanical wearing parts and increase machine changeover capability.

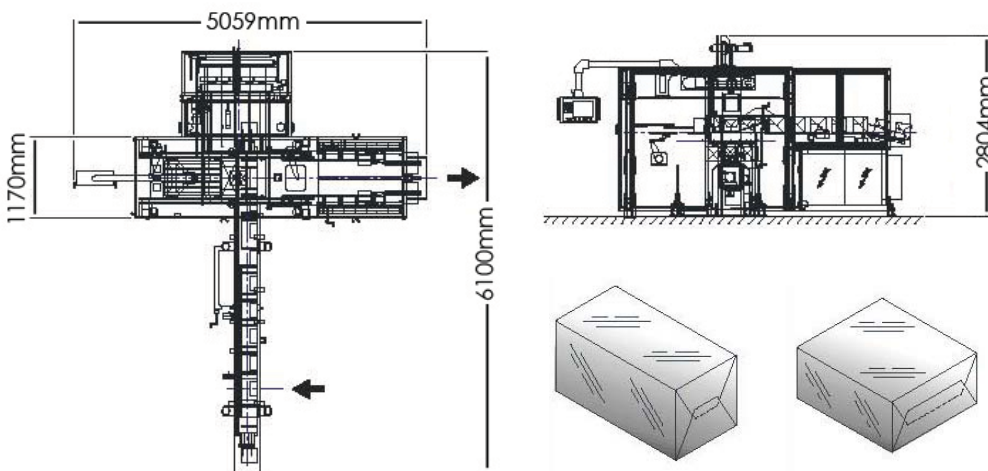

Standard Features:

- Automatic Infeed Unit
- Unwind Unit
- Poly Infeed Station
- Pushing Unit
- Bucket Elevator
- Poly Folding Section
- Upper Bucket
- Lower Sealing Station
- Side Folder Station
- Side Sealing Station
- Operator Panel

Machine Range:

- Width: 100mm - 230mm
- Length: 200mm - 500mm
- Height: 85mm - 230mm

Wrapping Material:

- Polyethylene (PE)
- Polypropylene (PP)
- Polypropylene (OPP)

Changeover Time:

- 15 minutes average
- 30 minutes maximum

Parent Roll:

- Maximum diameter: up to 600mm
- Width: up to 880mm
- Core diameter: 70mm to 76mm
- Poly print repeat: 325mm to 750mm

Parent Roll Change:

- approximately 3 minutes

Print Centering:

- +/- 3mm



C. G. Bretting Manufacturing Co., Inc.

3401 Lake Park Road • Ashland, Wisconsin 54806
Tel: 715.682.5231 • Fax: 715.682.4138
E-mail: cgb@bretting.com • www.bretting.com